

**CARBON STEEL GLOBE VALVE PN40**

ISO 9001  
BUREAU VERITAS  
Certification



**Size :** DN 15 to DN 200  
**Ends :** Flanges R.F. PN40  
**Min Temperature :** - 20°C  
**Max Temperature :** + 400°C  
**Max Pressure :** 40 Bars  
**Specifications :** Non rising stem  
Bolted bonnet and gland pack  
Stainless steel stem and seat

**Materials :** Carbon steel

**CARBON STEEL GLOBE VALVE PN40**

**SPECIFICATIONS :**

- Respect the flow direction indicated by the arrow
- Non rising stem
- Bolted bonnet and gland pack
- Stainless steel stem and seat
- Pressed seat in the body
- Flanges R.F. PN40
- RAL 5002 blue painting, 15µ thickness

**USE :**

- Common fluids of 2<sup>nd</sup> group
- Min and max Temperature Ts : - 20°C to + 400°C
- Max Pressure Ps : 40 bars ( see graph under )
- Keep greased the stem
- Not for thermic fluids
- Tighten the gland packing during setting

**FLOW COEFFICIENT Kvs ( M3/h ):**

DN	15	20	25	32	40	50	65	80	100	125	150	200
Kvs ( m3/h )	4	7	11	19	30	46	70	115	150	220	310	675

**PRESSURE / TEMPERATURE GRAPH :**

**Pression**

**(Bar)**

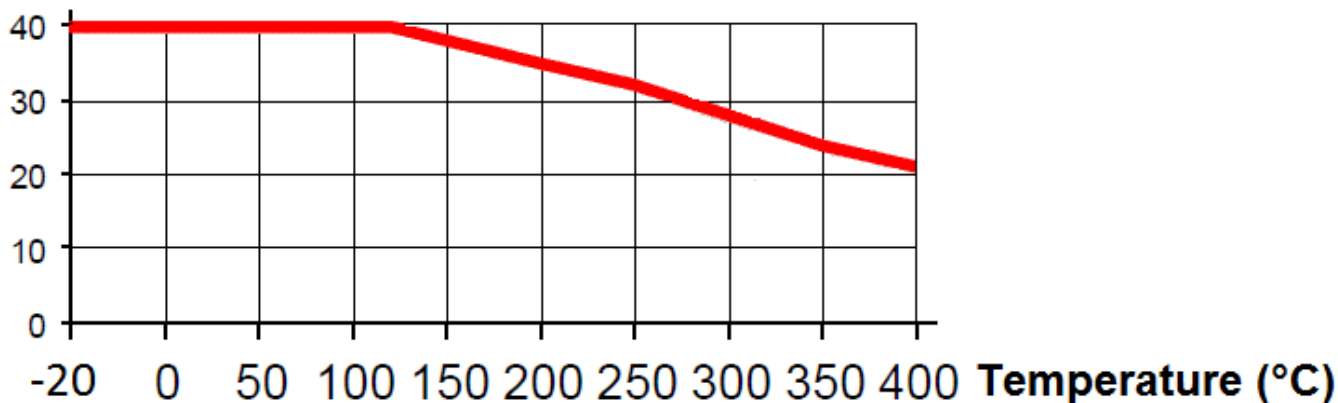

**RANGE :**

- Carbon steel globe valve flanges R.F. PN40 from DN 15 to DN 200 **Ref. 471**

**CARBON STEEL GLOBE VALVE PN40**

**MATERIALS:**

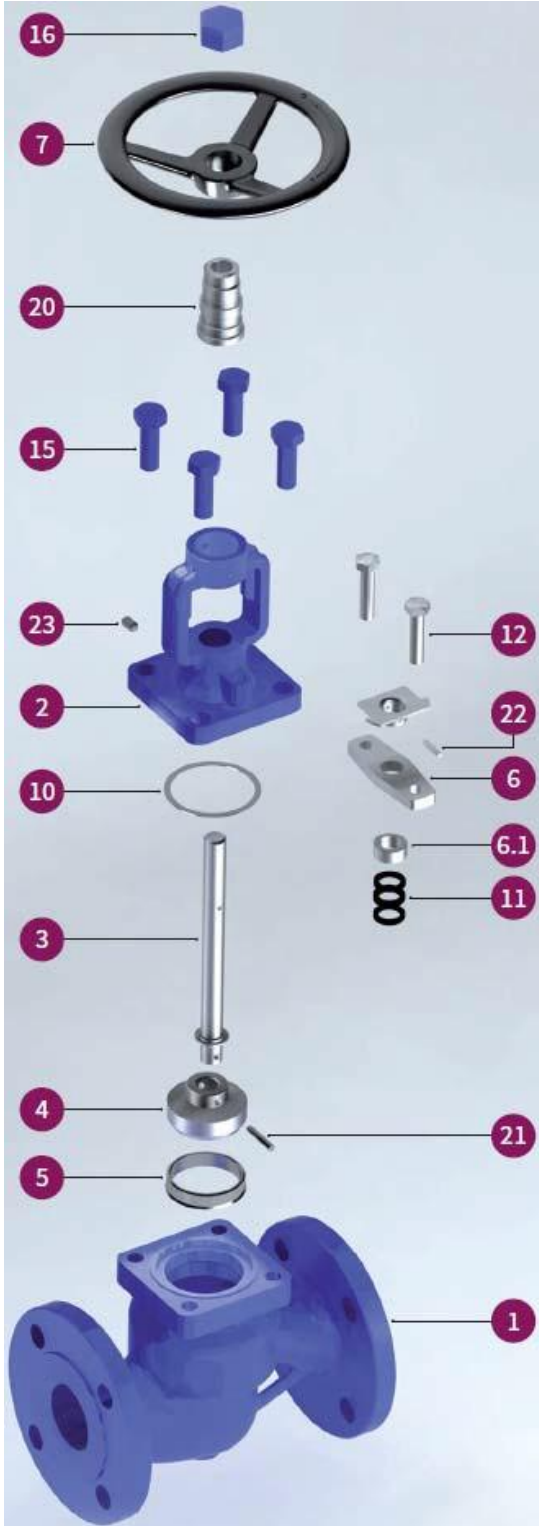

Item	Designation	Materials
1	Body	ASTM A216 WCB ( 1.0619 )
2	Bonnet	ASTM A216 WCB ( 1.0619 )
3	Stem	SS 303 ( 1.4305 )
4	Disc	SS 420 ( 1.4021 )
5	Seat	X 22 CrNi 17 ( 1.4059 )
6	Gland	EN 10025
6.1	Gland ring	EN 10087
7	Handwheel	EN GJS-400
10	Gasket	Graphite
11	Packing	Graphite
12	Gland bolts	5.6
15	Bonnet bolts	8.8
16	Handwheel nut	EN 10087
20	Threaded bushing	EN 10087
21	Pin	SS 304
22	Pin	SS 304
23	Lubricator	-

**CARBON STEEL GLOBE VALVE PN40**

SIZE ( in mm ):

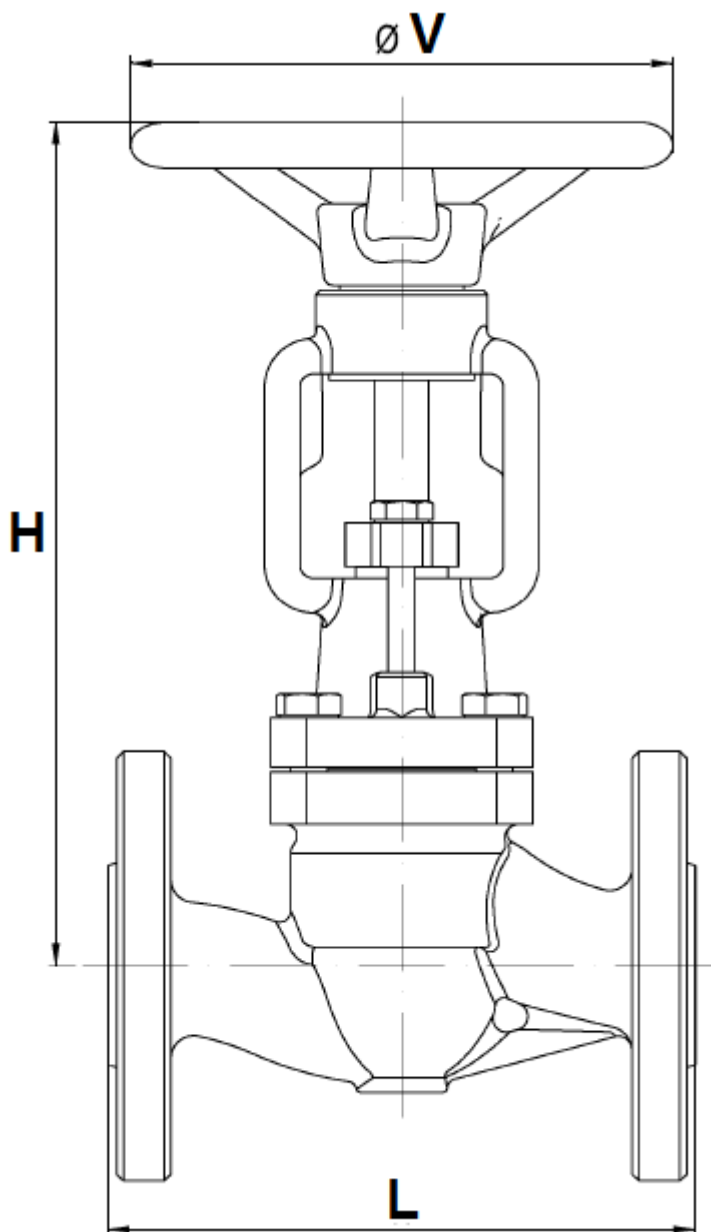

Ref.	DN	15	20	25	32	40	50	65	80	100	125	150	200
471	L	130	150	160	180	200	230	290	310	350	400	480	600
	H	190	195	220	219	254	265	328	341	376	488	531	663
	$\varnothing V$	140	140	140	140	180	180	200	200	250	330	330	400
	Weight (Kg)	3.5	4.3	6.3	7.3	12.5	15	22.5	27.5	42	67	99	200

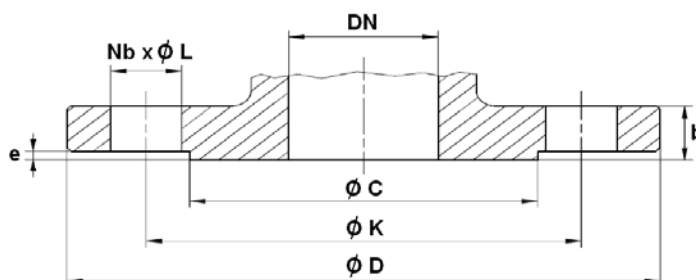
**CARBON STEEL GLOBE VALVE PN40**
**FLANGES SIZE ( in mm ) :**

DN	15	20	25	32	40	50	65	80	100	125	150	200
Ø C	45	58	68	78	88	102	122	138	162	188	218	285
Ø D	95	105	115	140	150	165	185	200	235	270	300	375
Ø K	65	75	85	100	110	125	145	160	190	220	250	320
Nb x Ø L	4 x 14	4 x 14	4 x 14	4 x 18	4 x 18	4 x 18	8 x 18	8 x 18	8 x 22	8 x 26	8 x 26	12 x 30
b	16	18	18	18	18	20	22	24	24	26	28	34
e	2	2	2	2	3	3	3	3	3	3	3	3

**STANDARDS :**

- Fabrication according to ISO 9001 :2008
- Designing according to DIN 3840
- Marking according to EN 19
- DIRECTIVE 97/23/CE : CE N° 0056  
Risk category III Module H
- Pressure Tests according to EN 12266-1, range A
- Length according to EN 558 series 1 ( DIN 3202 F1 )
- Flanges R.F. according to EN 1092-1 PN40
- Approval certificate Russian Federation **GOST-R**

**ADVICE :** Our opinion and our advice are not guaranteed and SFERACO shall not be liable for the consequences of damages. The customer must check the right choice of the products with the real service conditions.

## CARBON STEEL GLOBE VALVE PN40

### INSTALLATION INSTRUCTIONS

#### GENERAL GUIDELINES :

- Ensure that the valves to be used are appropriate for the conditions of the installation (type of fluid, pressure and temperature).
- Be sure to have enough valves to be able to isolate the sections of piping as well as the appropriate equipment for maintenance and repair.
- Ensure that the valves to be installed are of correct strength to be able to support the capacity of their usage.
- **Installation of all circuits should ensure that their function can be automatically tested on a regular basis (at least two times a year).**

#### INSTALLATION INSTRUCTIONS :

- **Before installing the valves, clean and remove any objects from the pipes** (in particular bits of sealing and metal) which could obstruct and block the valves.
- **Ensure that both connecting pipes either side of the valve (upstream and downstream) are aligned (if they're not, the valves may not work correctly).**
- **Make sure that the two sections of the pipe (upstream and downstream) match, the valve unit will not absorb any gaps. Any distortions in the pipes may affect the tightness of the connection, the working of the valve and can even cause a rupture.** To be sure, place the kit in position to ensure the assembling will work.
- **If sections of piping do not have their final support in place, they should be temporarily fixed. This is to avoid unnecessary strain on the valve.**
- Tighten the bolts in cross.
- It's recommended to operate the valve ( open and close ) 1 to 2 times per year
- Tighten the gland packing at the first start of the installation ( with a moderate torque ) so that there's no leakage and the handwheel is easy to operate.
- Do not use tools to operate the handwheel
- Respect the flow direction indicated by the arrow