

PRESSURE GAUGES WITH ELECTRICAL ALARM CONTACT

with or without dampening
for the chemical industry



Diameter 100, 160
with magnetic snap-action contacts
or inductive alarm contacts

Connection position radial bottom



Description

The design principle and material selection of the diaphragm pressure gauges allow them to meet the stringent demands occurring above all in the chemicals and petrochemicals industries.

Special corrosion resistant materials protect the wetted parts in service with chemically aggressive media. Open process connections ensure that the gauges are easy to clean with highly viscous or crystallizing process media, thus guaranteeing process reliability.

The diaphragm system makes the gauges extensively insensitive to vibration or jarring and produces a high level of over-pressure protection and actuating force. As a result of the high actuating force, diaphragm pressure gauges are particularly suitable for connection of electric alarm contacts. Electric alarm contacts open and close circuits in response to the position of the pressure gauge pointer.

Magnetic snap-action electric alarm contacts are predominantly used in adverse operating conditions. The high contact pressure and the selection of various contact materials result in reliable and cost effective solutions, above all when high currents have to be switched. Signal output can however take place slightly in advance of or lagging slightly behind the motion of the actual value pointer.

If the electrical switching capacities of the alarm contacts are exceeded or not reached (technical Information – chapter 8) is to use a contact protection relay to provide an appropriate current rating.

Inductive electric alarm contacts have an almost unlimited service life, as the signal is switched without physical contact. Closing or opening takes place without any feedback effect of the measuring system, precluding any signal lead or lag. A corresponding control unit is always required for operation. Units with inductive contacts may be operated in areas with potentially explosive atmospheres, assuming compliance with existing specifications.

Features

- o Limit value signalling by magnetic snap-action or inductive contacts
- o With SVA-amplifier suitable for SPS control units
- o Up to 4 alarm contacts possible
- o Can be used under Ex-conditions with inductive alarm contacts
- o Liquid dampening provides vibration-free display.
- o Up to 10-fold overload capacity
- o Measuring system stainless steel 1.4571
- o Protection class IP 54 resp. IP 65

Ranges

0 ... 16 mbar up to 0 ... 40 bar

Applications

Chemical and petrochemical industry,
food and beverage industry,
mechanical engineering, plant and apparatus
construction

Technical details

Types	4312	4412	4312	4412	4512	4612	4512	4612	Options
Diameter	100				160				
Symbol									
Type of contact	Magn. -snap		Induktive		Magn. -snap		Induktiv		
Number of contacts	1 to 4 depending on measuring range		1 to 3 depending on measuring range		1 to 4 depending on measuring range		1 to 3 depending on measuring range		
Liquid filling	-	Ester oil	-	Ester oil	-	Ester oil	-	Ester oil	
Electrical connection	cable connector right hand side 6 screw terminals +PE, cross section of conducting wire 2,5 mm ² Cable gland M 20 x 1.5 outgoing downwards								back (without pressure relief opening)
Accuracy class	Class 1,6 acc. to EN 837-3, Class 2,5 with liquid filling and measuring ranges from 0...25 mbar to 0...100 mbar								
Ranges	0...25 mbar to 0...250 mbar : flange Ø 160 mm 0...0,4 bar to 0...40 bar: flange Ø 100 mm negative or positive and neg. und pos. overload								
Application	Constant load: up to full scale value Alternating load: 0,9 x full scale value								
Overload protection	5 x full scale value, but max. 40 bar								overload: 10x full scale value; max. 40 bar, vacuum proof to - 1 bar
Case and upper flange	Stainless steel, pure, with pressure relief								
Conection with lower flange - Position - Thread	Stainless steel, 1.4571 bright								Other threads or open flanges on request
	Bottom, radial								
	G 1/2 B, SW 22								
Ring	Stainless steel, bright, bayonet ring								
Window	Laminated safety glass								
Dial	Al white, scale and markings black								Dual scale
Pointer	Al black								
Movement	Stainless steel								
Elastic measuring element	≤ 2,5 bar: stainless steel 1.4571 > 2,5 bar: stainless steel (Duratherm 600)								
Seal to - pressure chamber - internal chamber	FPM (Viton) NBR (Perbunan)								PTFE Metal bellow (stainless steel)
Medium temp.	T _{min} -20°C, T _{max} 100 °C								
Ambient temp.	T _{min} -20°C, T _{max} 60°C								
Temperature drift	0,5%/10K if deviation of normal temperature 20°C								
Protection acc. EN 60 529/ IEC 259	IP 54	IP 65	IP 54	IP 65	IP 54	IP 65	IP 54	IP 65	
Wetted appts	See process connection with lower flange and elastic measuring element								Special materials on request
Orifice									Ø 0,4; Ø 0,8 mm

Measuring range	Magnatic snap-action contact	Inductive contact
16 mbar	2	3
ab 40 mbar	4	3

Electrical details and accessories - see "Technical Information"

Dimensioned drawings

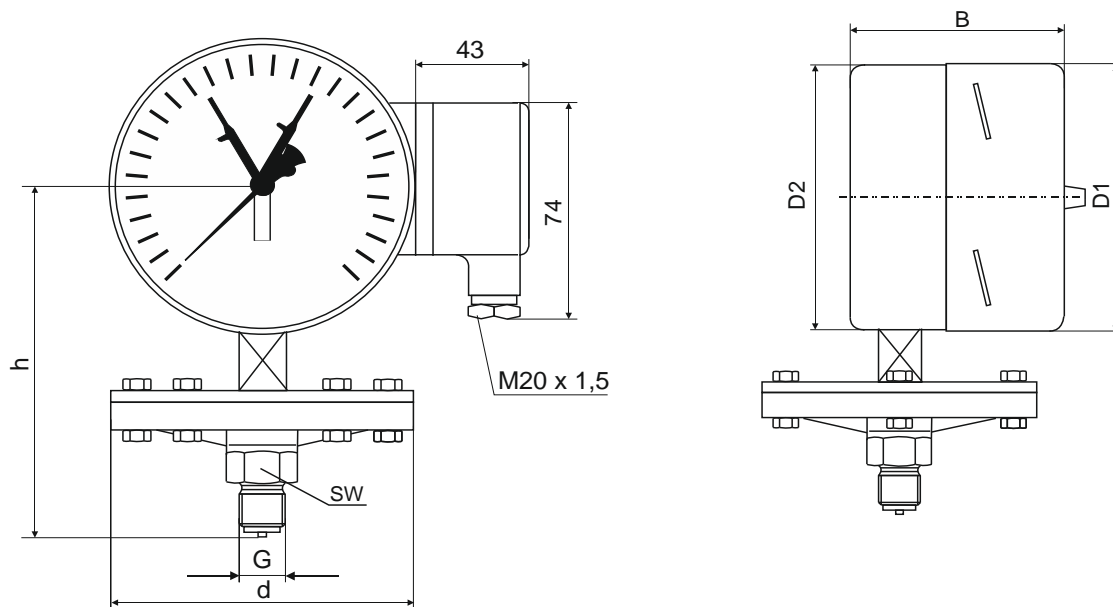

ND	Measuring range (bar)	Dimensions (mm)							Approx weight (kg)				
		d	B±1 with		D1	D2	G	h±2	SW	unfilled, with		filled, with	
			1+2 cont.	3 cont.						1+2 cont.	3 cont.	1+2 cont.	3 cont.
100	≤0,25	160	88	96	101	99	G1/2B	117	22	2,9	3,0	3,4	3,5
160			101	101	161	159		149		3,5	3,6	5,1	5,2
100	> 0,25	100	88	96	101	99	G1/2B	117	22	1,7	1,8	2,2	2,3
160			101	101	161	159		149		2,3	2,4	3,9	4,0

Connection acc. to EN 837 / 3

Optional DIN-flange connection DN 25, PN 10 bis PN 40

Ranges 0...25 up to 0...250 mbar

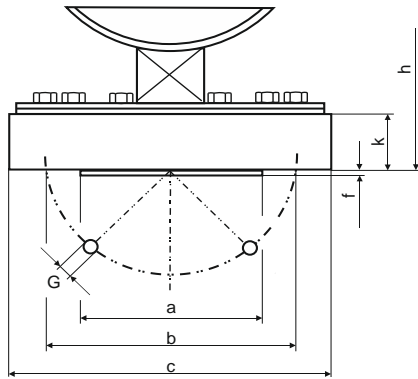

Ranges 0...0,4 up to 0...40 bar

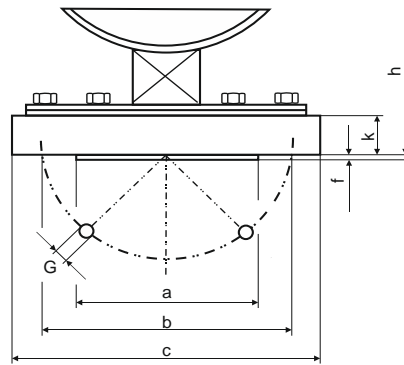

ND	DIN-flange DN 25 PN 10 up to 40 ¹⁾	Dimension in mm							Approx. weight ²⁾ (kg)
		a	b	c	f	k	G	h±2	
100	≤0,25 bar	68	85	160	2	36	4 x M12	122	3,0
160								152	
100	> 0,25 bar	68	85	115	2	25	4 x M12	111	0,9
160								141	

Other dimensions as standard type

Optional DIN-flange connection DIN DN 50, PN 10 up to PN 40

Ranges 0...25 up to 0...250 mbar

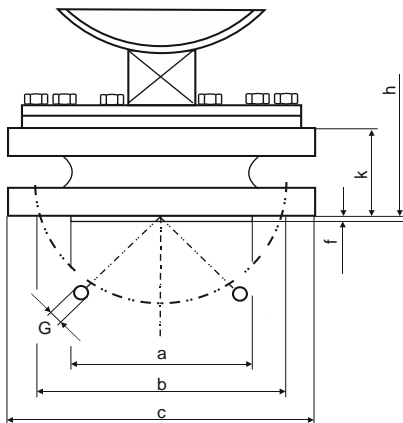

Ranges 0...0,4 up to 0...40 bar

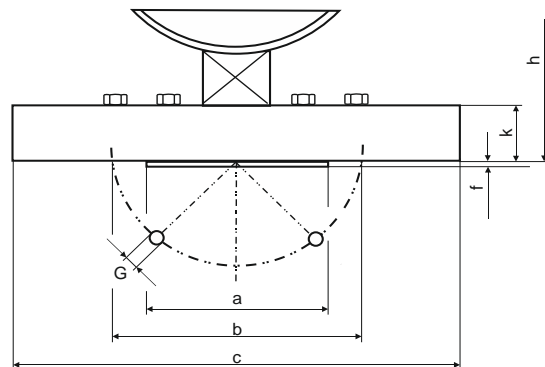

ND	DIN-flange DN 25 PN 10 up to 40 ¹⁾	Dimension in mm							Approx. weight ²⁾ (kg)
		a	b	c	f	k	G	h±2	
100	≤0,25 bar	102	125	165	54	3	4 x Ø 18	140	3,0
160								170	
100	> 0,25 bar	102	125	165	30	3	4 x Ø 18	106	2,5
160								136	

Other dimensions as standard type

1) Flanged to DIN flange , seal form D according to DIN 2526

2) The specified weights are additional materials to the weight of the standard version (with connection G1 / 2B).